

FAST ORBIT FEEDBACK AT TAIWAN PHOTON SOURCE

A.Bardorfer, P. Leban, Instrumentation Technologies, Solkan, Slovenia
K.T.Hsu, C.H.Kuo, P.C.Chiu, NSRRC, Hsinchu, Taiwan

Abstract

Low latency, distributed, Fast Orbit Feedback (FOFB) application, based on singular value decomposition, entirely implemented in FPGA, has been developed for the Taiwan Photon Source (TPS). The FOFB utilizes Instrumentation Technologies' latest Libera Brilliance+ units for measuring beam position and the Gigabit Data eXchange (GDX) modules, which take care of global orbit distribution via 6.5 Gbit/s fiber optic or passive Cu links, and provide a large orbit data history buffer. The magnet correction in a matrix form of $M=V.PI(S^{-1}.U^T.dP)$ is calculated entirely in FPGA, using a massively parallel approach and sent to the magnet power supplies via 2.5 Gbit/s link. The entire FOFB calculation is distributed over 48 GDX modules and the system allows for synchronous (on/off/pause) FOFB control via external input signal. The latencies of 60 ns per BPM for orbit distribution, 1.5 μ s for FOFB calculation and 1.5 μ s for magnet data transmission have been measured at TPS test installation in November 2012. The expected total communication and FOFB calculation latency in the TPS final configuration (168 BPMs) is expected to stay within 15-20 μ s range.

SYSTEM OVERVIEW

The TPS storage ring will use a 24-cell DBA lattice and will have 24 straight sections for insertion devices, six of them 12 m-long and 18 of them 7 m-long. It will be a combined-function magnets lattice structure with 10 nm rad emittance and will be located in the inner tunnel of the TPS storage ring [1].

The Libera Brilliance+ instrument is a high-performance beam position processor used in the TPS. It provides wide and narrow bandwidth data paths with sub-micron turn-by-turn position measurement and sub-micron long-term stability [2]. The source data for the fast orbit feedback (FOFB) application is a data stream with 10 kSamples/s data rate and 2 kHz bandwidth with position resolution less than 100 nm.

The FOFB capability is provided by an extension module – the Gigabit Data Exchange (GDX) module. The GDX module receives position data streams over Low-voltage Differential Signalling (LVDS) links to ensure low latency [3]. The module contains Virtex6 field programmable gate array (FPGA) with TPS custom-made FOFB application. There is also 1 GB memory available to buffer the fast data streams. The module features 4x SFP cages that are protocol and data rate independent. Two of these SFPs are used for fast orbit data concentration (6.5 Gbit/s), one is configured for global orbit position data output (Gigabit Ethernet) and one for magnet data output (2.5 Gbit/s).

CONTROL TOPOLOGY

The Libera Brilliance+ instruments are daisy-chained with 6.5 Gbit/s fibre optic or copper cables to form a single group of 168 BPMs installed in 48 units. Each instrument runs the EPICS IOC and communicates over GbE network interface to the Control System. The fast position data exchange and matrix multiplications are implemented in the FPGA in the GDX module to ensure lowest latency possible. FOFB related parameters such as matrix configurations, PI controller coefficients and reference orbit setting are controlled by Libera BASE software, running in the Libera Brilliance+. All parameters can be accessed and controlled through EPICS or alternatively, through custom interface that talks directly to Libera BASE.

Each cell contains 2x Libera Brilliance+ with 3 or 4 BPM modules and 1 GDX module. The FOFB application is configured to calculate and output the data for either horizontal or vertical fast corrector magnets. Calculations are done in a distributed manner so each of the 48 GDX modules provides the data for its local 4 fast corrector magnets. Fast corrector magnets are controlled by a Corrector Power Supply Controller (CPSC) device which features 2 optical inputs (SFPs) and 8 analogue outputs (20 bit) [4]. One input receives the data for horizontal magnets, the other for the vertical magnets. Figure 1 shows the local control topology and connections between the CPSC and the GDX modules.

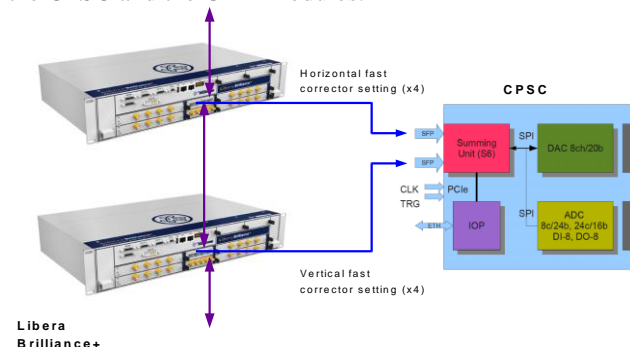

Figure 1. Local control topology

The FOFB application is flexible in terms of the number of calculated magnets and matrix sizes (up to 256 BPMs and 128 magnets).

The FOFB application output is controlled by either software switch or hardware signal. Control with hardware signal is beneficial to ensure simultaneous FOFB loop switch ON/OFF on all instruments. The hardware signal is provided to the timing module and distributed to the GDX module via Libera Brilliance+ backplane. Multiple copies of the same global orbit data

are present in each GDx module and can be output via UDP/IP as a data stream.

IMPLEMENTATION

The source of the fast orbit feedback loop is the beam position data stream with 10 kSamples/second data rate. The data stream is lead from the BPM modules over LVDS connections to the GDx module. The data content after the data concentration includes horizontal and vertical positions (X, Y), SUM and status. The Libera Grouping is the FPGA block that uses two Small form-factor pluggable transceivers (SFPs) to communicate with its neighbours at 6.5 Gbit/s rate. It concentrates the beam position data from all daisy-chained instruments and forms a global orbit data packet. The design includes a measurement of the time needed to concentrate all BPM data. This time can be interpreted as the Libera Grouping latency. The global orbit data packet is then immediately output to a dedicated GbE link which is configured for UDP/IP at 1 Gbit/s. Due to standard protocols used the orbit position data stream can be received with a standard Windows or Linux based PC with jumbo-frame compatible network interface.

Further down the matrix multiplication scheme (Figure 2), the orbit position data is compared to the golden orbit (reference orbit) and its diff enters the matrix multiplication block. The transform matrix from orbit reading to magnet correction is:

$$M_{cx1} = V_{cxe} \cdot PI_{ex1} (S_{m \times n}^{-1} \cdot U_{n \times n}^T \cdot dP_{n \times 1})$$

The position delta (dP) is first multiplied with almost diagonal matrix of singular values ($S^{-1} \cdot U^T$) which transforms the data from BPM to eigen mode space. The PI controllers are applied to the multiplication result. In the end, multiplication with the V matrix transforms the data from the eigen mode space to the corrector magnet space and selects which magnet correction is sent to the output.

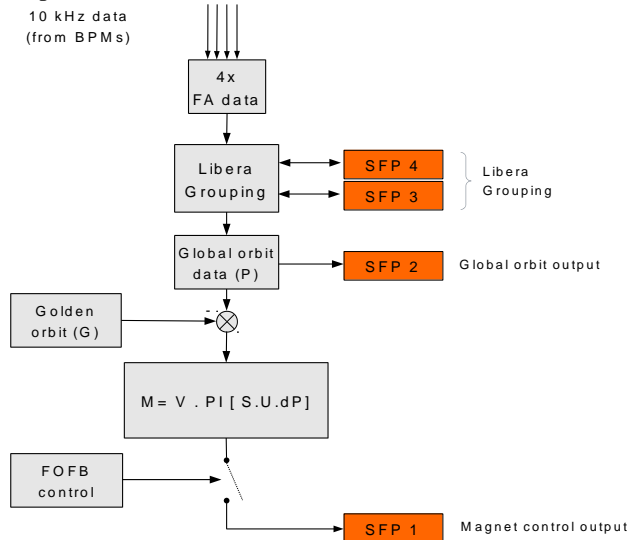

Figure 2. Implementation scheme

The multiplication scheme is flexible in terms of the number of BPMs, magnets and eigen modes. It can output corrections for all magnets or just for local ones. The selection is done with a dedicated filter which in the end equips the data packets with corresponding magnet IDs. The magnet correction output is sent through the SFP1, which is configured for AURORA protocol at 2.5 Gbit/s.

Such approach requires several multiplications of big matrices (up to 128 x 256) but it is designed to do all multiplications in parallel. This was done to reduce the calculation time (calculation latency) to the minimum possible extent. It is estimated that the calculation latency is 2 μ s at maximum number of elements and approximately 1.5 μ s for the TPS storage ring configuration (96 x 168).

The multipliers used are 18 x 25 bits. The design contains several checkpoints that detect saturation after critical multiplication steps. Whenever necessary, bit width is narrowed to fit multipliers.

Control over matrices is fully supported by the EPICS IOC as well as all the parameter settings [5].

OPEN LOOP RESULTS

Initial tests covered the global orbit data output and matrices-calculation part including PI controller settings. The global orbit data packet supports up to 253 BPM IDs in a single packet. Each BPM ID data packet includes 16 bytes of data (4x 4B) – status, X position, Y position and SUM. The BPM IDs in the global orbit data packet are sorted in ascending order. All tests were done in an open loop (without feeding the results back to actuators). Matrices were set up in such way that a selection of magnet IDs were sent to output. FOFB related parameters (K_p , K_i , S, U, V, G) were set during the tests to observe the anti wind-up behaviour of the PI controller and output response with different K_p and K_i values.

The anti wind-up protection has been added to the PI controller to protect the I-term accumulation once the saturation of the actuator has been detected. Once the saturation (negative or positive) has been detected, the I-term stops the accumulation and sets the saturation flag which remains latched until user's reset. The output of the PI controller immediately follows the change in delta position (reference orbit – real orbit). See transitions marked with arrows in Figure 3.

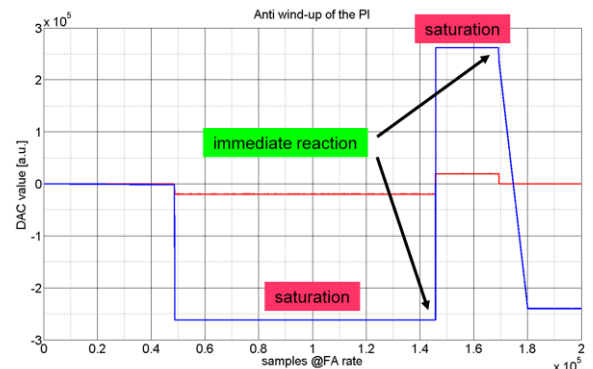

Figure 3: Anti wind-up of the PI controller

To test various settings of the PI controller, a sine-wave input signal was used. The reference orbit was kept at 0 nm. For more illustrative comparison, the FOFB matrices were set to output the data for two magnets, each having different K_p and K_i values but taking the source data from the same BPM ID. Results are shown in Figure 4. The red output had only the proportional term set and was following the input signal (1 second period). The green output had only the integral term set and was integrating the error. Flat regions in green output correlate with region where the red output is around 0 (and delta position is also around 0).



Figure 4: P & I term test

EXPERIMENTAL CLOSED LOOP TEST

113 BPMs were connected to the single group. Data concentration and FOFB calculation latency measured was about $7 \mu s$ which yields about 62 ns per BPM. Same result was obtained with group size reduced to 60 BPMs. The latency depends on the population of BPM modules within one Libera Brilliance+ chassis (more BPM modules, less latency per BPM). Best results were achieved with 4 BPMs per chassis.

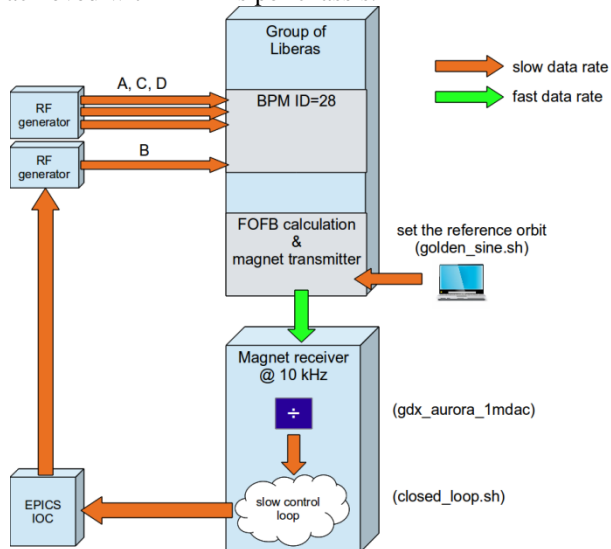

Figure 5: Experimental (slow) closed loop

The experimental closed loop was arranged with a group of Libera Brilliance+, magnet data receiver and EPICS-controlled signal generator. The FOFB matrices

were arranged to output one magnet and send the data to the receiver which translated the DAC value to scaled value which was then pushed to the EPICS-controlled signal generator. In the end, the signal generator “corrected” the channel amplitude and finally the BPM position. All data links except the magnet output – magnet receiver link were slow (8 – 10 Hz) since the CPSC unit was not available at present moment. See Figure 5.

To confirm correct magnet output behaviour, the reference orbit was controlled by external process (from PC) in order to generate orbit error. The real orbit was correctly following the reference orbit. Larger I-term values resulted in short response to orbit error but caused larger overshoot (left part of Figure 6). On the other hand, softer response was recorded with smaller I-term value (left part of Figure 6).

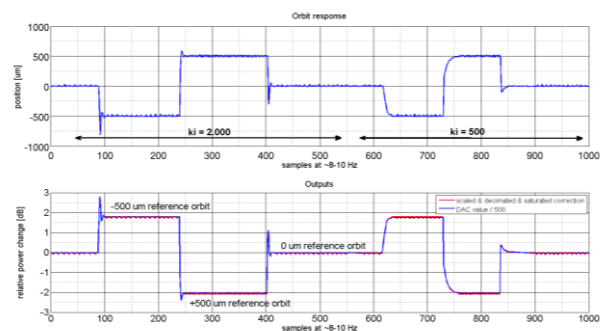

Figure 6: Closed loop results of position and magnet readout

CONCLUSION

The FOFB application has been installed in the Libera Brilliance+ instruments at NSRRC TPS in November 2012 with successful initial test results. The data concentration and calculation latency results were in the range of 60 ns per BPM which extrapolates to less than 20 μs latency for the whole system of 168 BPMs. Final installation and system integration of the TPS accelerator systems is scheduled in late 2013. Commissioning will be performed in 2014. FOFB is planned to be tested at early commissioning phase. Operational FOFB is expected from day one of user service.

REFERENCES

- [1] TPS Design Handbook, version 16, June 2009.
- [2] Libera Brilliance+ documentation, <http://www.i-tech.si>.
- [3] GDX Module Specifications, <http://www.i-tech.si>.
- [4] CPSC module Specifications, <http://www.d-tacq.com>.
- [5] P.Leban et al., “Fast Orbit Feedback Calculation Implementation for TPS”, Proc. of IBIC’12, Tsukuba, October 2012, TUPA33.