

# STABILITY TESTS WITH PILOT-TONE BASED ELETTRA BPM RF FRONT END AND LIBERA ELECTRONICS

M. Cargnelutti\*, P. Leban, M. Žnidarčič, Instrumentation Technologies, Solkan, Slovenia  
 S. Bassanese, G. Brajnik, S. Cleva, R. De Monte, Elettra-Sincrotrone Trieste, Trieste, Italy

## Abstract

Long-term stability is one of the most important properties of the BPM readout system. Recent developments on pilot tone capable front end have been tested with an established BPM readout electronics. The goal was to demonstrate the effectiveness of the pilot tone compensation to varying external conditions. Simulated cable attenuation change and temperature variation of the readout electronics were confirmed to have no major effect to position data readout. The output signals from Elettra front end (carrier frequency and pilot tone frequency) were processed by a Libera Spark with the integrated standard front end which contains several filtering, attenuation and amplification stages. Tests were repeated with a modified instrument (optimized for pilot tone) to compare the long-term stability results. Findings show the pilot tone front end enables great features like self-diagnostics and cable-fault compensation as well as small improvement in the long-term stability. Measurement resolution is in range of 10 nanometers RMS in 5 Hz bandwidth.

## INTRODUCTION

The recent developments about eBPMs analog front ends capable of pilot tone compensation [1, 2] have shown a growing interest towards this topic. In order to verify the usefulness of this approach and its benefits with an existing BPM readout electronics, the eBPM analog front end developed at Elettra has been coupled with an Instrumentation Technologies' Libera Spark.

## ELETTRA EBPM RF FRONT END

The front end is similar to the one presented at IBIC 2016 [2], but enhanced and re-engineered in a more compact solution. In the present version the low-noise PLL has been integrated in the box, together with diagnostic functionalities (voltage and temperature sensors) and complete Ethernet control. Figure 1 shows the block diagram of the system: a low-phase-noise PLL (7) generates the pilot tone (whose frequency and amplitude are programmable), which is split into four paths by a high-reverse-isolation splitter (6) that guarantees more than 52 dB of separation between the outputs. A coupler (2) sums the tone with the signal from the pick-ups, adding further 25 dB of isolation to prevent inter-channel crosstalk from the path of the pilot tone. At this point, all the signals pass through a bandpass filter (3), centered at 500 MHz with a bandwidth of 15 MHz, and two variable-gain stages, composed of low-noise, high-linearity amplifiers (5) ( $G=22$  dB,  $F=0.5$  dB,  $OIP_3=+37$  dBm,  $P_{1dB}=+22$  dBm) and

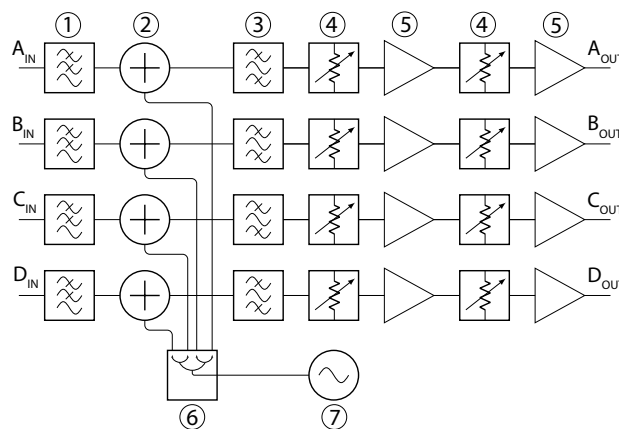

Figure 1: Analog front end block diagram.



Figure 2: Frequency response of the front end at full gain.

digitally controlled attenuators (4) (7 bits, up to 31.75 dB of attenuation, steps of 0.25 dB).

In order to achieve the expected results, the splitter must be temperature-insensitive, as well as the four couplers. Indeed, this architecture allows us to compensate the part of the system after the couplers, i. e. filters, attenuators, amplifiers. It has to be noted that being the front end a separate unit, it can be placed as near as possible to the pick-ups (tunnel area), with two main advantages: better signal-to-noise ratio and the possibility to compensate the cables (which are usually long). The frequency response of the front end is shown in Fig. 2.

## LIBERA ELECTRONICS

Libera Spark was used to process the A, B, C and D signals from the Elettra eBPM analog front end. Libera Spark is

\* manuel.cargnelutti@i-tech.si

Content from this work may be used under the terms of the CC BY 3.0 licence (© 2018). Any distribution of this work must maintain attribution to the author(s), title of the work, publisher, and DOI.

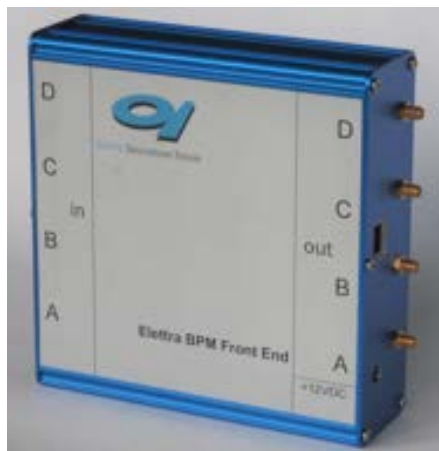

Figure 3: Elettra eBPM analog front end.

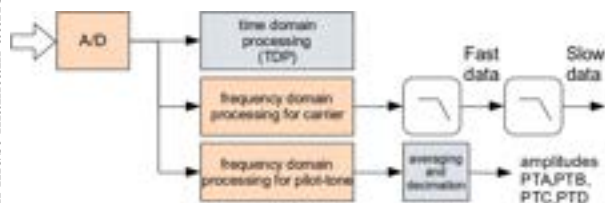

Figure 4: Double DDC processing.

a standard beam position processor used in several synchrotron lightsources and provides data from turn-by-turn down to slow data streams [3,4]. Initial measurements were done with a standard unit. Raw ADC data was taken periodically over several hours and post analysed. Position was calculated in frequency domain by measuring the frequency components of the carrier frequency (RF, 499.654 MHz) and of the pilot tone's frequency (PT, 501.282 MHz). The sampling frequency was set to 116.8 MHz and was not locked to any external reference clock (normally it should be). First results of combined tests (Elettra eBPM analog front end and Libera Spark) were encouraging and show several benefits. To ease further analyses, a new digital-down-conversion processing branch was implemented in the programmable logic (FPGA) of the Libera Spark which was then able to process the RF and PT in frequency domain (independently) and A/D data in time-domain which ensures clean turn-by-turn measurement. As a proof-of-principle, the implementation was simplified and the PT DDC processing branch only outputs highly averaged A, B, C and D amplitudes at  $\sim 8.8$  Hz update rate (Fig. 4).

The DDC processing chain for the carrier frequency is tuned to the 32.38 MHz component which is then filtered and decimated in 2 stages to provide the user with fast (10-30 kHz) data streams and slow (10-40 Hz) data streams with narrower bandwidth. The  $-3$  dB bandwidth of the turn-by-turn data is approximately 350-400 kHz. The additional DDC processing chain is tuned to the 34.01 MHz component which comes from the pilot tone's frequency. For this test set, amplitudes (PTA, PTB, PTC, PTD) were only highly averaged and provided to user space with slow update rate. The

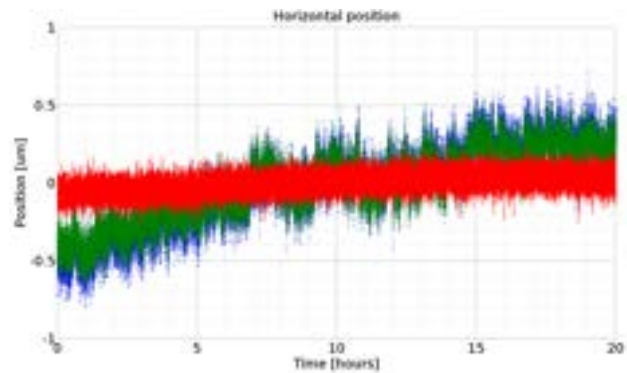

Figure 5: Horizontal position drift at 25 °C stable temperature.

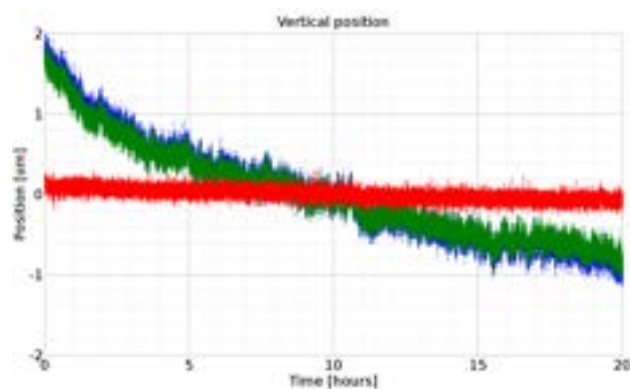

Figure 6: Vertical position drift at 25 °C stable temperature.

PTA, PTB, PTC and PTD were used for on-line compensation in the upper software layer (EPICS) so compensated data could be observed in quasi real-time. There was a little drawback in such simplified implementation (asynchronous amplitude update/calculation) but this will be easily fixed with complete FPGA implementation.

## TEMPERATURE COMPENSATION

A very important property of beam position processor is how calculated position drifts when environmental temperature changes. For evaluation and better understanding, we put the whole system inside the temperature chamber. First measurements were done at 25 °C stable temperature over 20 hours. For this test, all equipment, including the RF generator, were placed inside the chamber. Position data was taken every 1 second. Horizontal position data from the carrier (blue) and from the pilot tone (green) drifted for approximately 0.8  $\mu\text{m}$  (mean value) whereas the compensated position (red) showed an almost negligible drift of approximately 100 nanometers (Fig. 5). In vertical direction, the compensated position drifted for the same amount ( $\sim 100$  nanometers) but the carrier's and pilot tone's position drifted for about 3  $\mu\text{m}$ .

A more interesting measurement was done with a temperature profile. Temperature was changed in the range from 20 °C to 30 °C in 1 °C steps. Complete temperature profile is

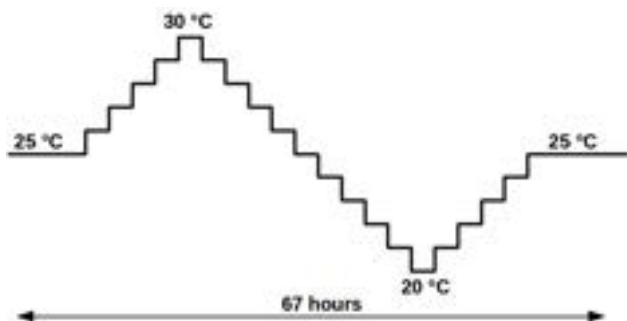

Figure 7: Long-term temperature profile.

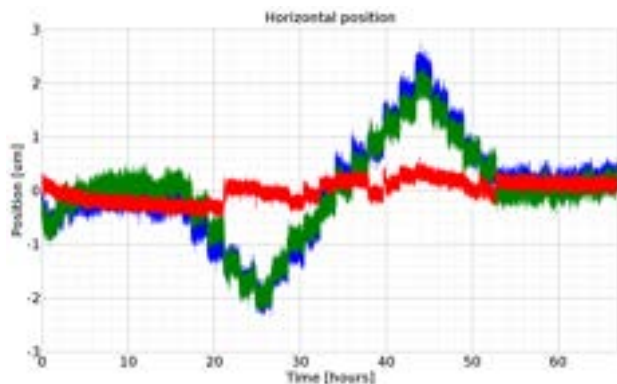

Figure 8: Horizontal position drift at temperature profile.

shown in Fig. 7. For this test, the RF generator and a 4-way splitter were put out of the temperature chamber and left at room temperature.

Carrier's and pilot tone's position drifted for  $2\ \mu\text{m}$  and  $4\ \mu\text{m}$  in horizontal and vertical directions, respectively ( $0.2\ \mu\text{m}/^\circ\text{C}$  and  $0.4\ \mu\text{m}/^\circ\text{C}$ ) while the compensated position drifted approximately  $0.8\ \mu\text{m}$  and  $1.5\ \mu\text{m}$ . in total over  $10^\circ\text{C}$  (horizontal and vertical, respectively). Obtained results show an improvement factor of 2 of original vs compensated position (as shown in Table 1). Taking into account typical environmental conditions, expected drift can be easily neglected.

Table 1: Position Drifts (Peak-to-Peak)

Position drift	Non-compensated	Compensated
Horizontal	$4\ \mu\text{m}$	$0.8\ \mu\text{m}$
Vertical	$2.5\ \mu\text{m}$	$1.5\ \mu\text{m}$

### CABLES WOBBLING

To demonstrate the validity of cable compensation, a coaxial cable connected between the front end and the Libera Spark was bent and wobbled. Figure 9 shows the position variation of the carrier and the pilot during this operation, with a peak-to-peak deviation of about  $6\ \mu\text{m}$ . Residual oscillations in the compensated positions have a deviation 10 times smaller (about  $500\ \text{nm}$  peak-to-peak), excluding the

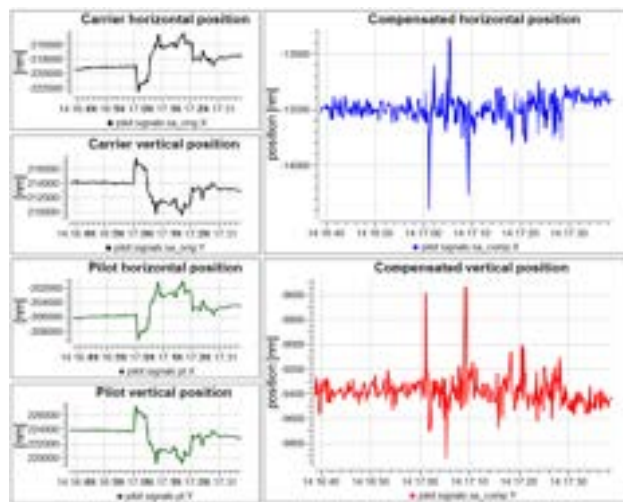

Figure 9: Cable wobbling.

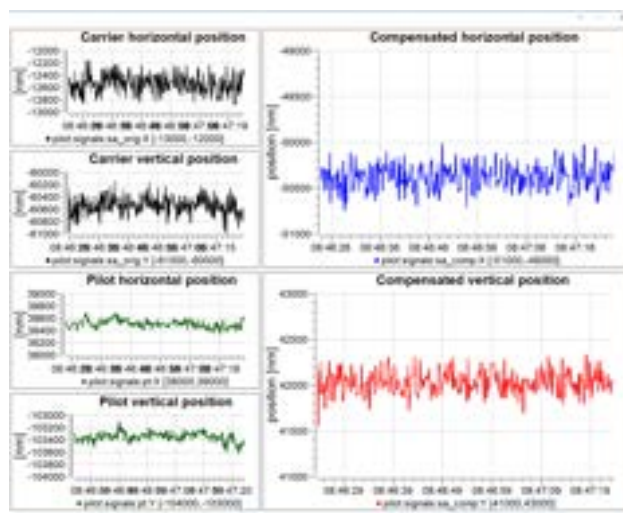

Figure 10: Noise on carrier and beam positions at different amplitudes.

spikes due to the asynchronous calculations as stated in previous sections.

### QUALITY OF THE MEASURE

Another interesting feature is in using pilot tone as an indication of the quality of the measure. In a traditional BPMs, is difficult to have a complete on-line indication of the correct behaviour of the system: if beam position has much noise than expected or weird deviations are noticed, doubts about a possible malfunction of the electronics will remain until a complete test on the unit will be done.

In Fig. 11, carrier amplitude has been deliberately reduced by more than 10 times, increasing the noise on it (about  $600\ \text{nm}$  peak-to-peak, Fig. 10). Since the noise on the pilot is in the expected range, it gives the indication that the system is functioning in a correct way, thus the carrier position behaviour is real.

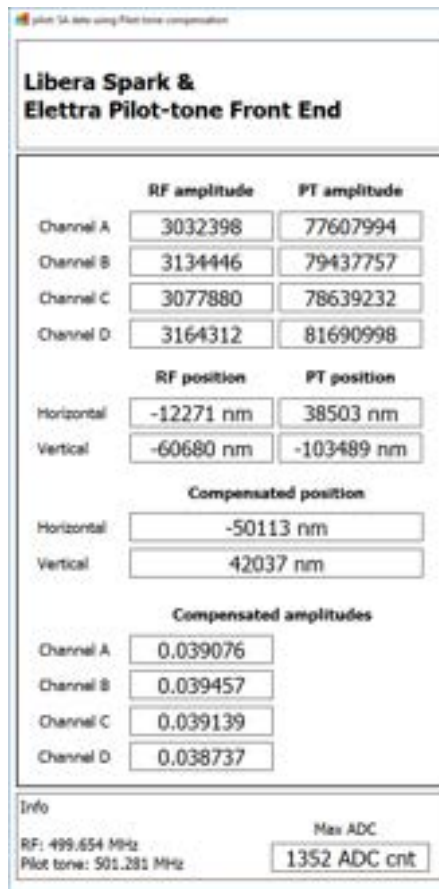

Figure 11: Difference of amplitude between carrier and pilot.

## CONCLUSION

The performed measurements with the pair Libera Spark-Elettra front end gave encouraging results, both in resolution

and in long-term performances, compensating external effects, but must be proved with beam. By modifying the analog front end of the Libera Spark the stability was improved by a factor of 10 or more. The next step will be a software update which will allow synchronous and hard real-time compensation. Furthermore, several new features are foreseen, such as dynamic change of the pilot tone's frequency and online monitoring of the measurement quality. There is also an option to develop a hardware module that fits in Libera Spark and provides the power, the communication and reference clock to the front end.

## REFERENCES

- [1] G. Brajnik, S. Carrato, S. Bassanese, G. Cautero and R. De Monte, "Pilot tone as a key to improving the spatial resolution of eBPMs", *AIP Conference Proceedings*, vol. 1741, p. 020013, 2016. doi:10.1063/1.4952792
- [2] G. Brajnik, S. Bassanese, S. Carrato, G. Cautero, and R. De Monte, "A novel electron-BPM front end with sub-micron resolution based on pilot-tone compensation: test results with beam", in *Proc. IBIC2016*, Barcelona, Spain, 2017, pp. 308–311. doi:10.18429/JACoW-IBIC2016-TUPG02
- [3] G. Jug, M. Cargnelutti and B.K. Scheidt, "Development of compact electronics dedicated to beam position monitors in injectors and boosters", in *Proc. IBIC2013*, Oxford, UK, 2013, paper WEPC18, pp. 713–715.
- [4] M. Cargnelutti and B.K. Scheidt, "Commissioning results of the new BPM electronics of the ESRF booster synchrotron", in *Proc. IPAC2015*, Richmond, VA, USA, 2015, pp. 24–27. doi:10.18429/JACoW-IPAC2015-MOAB3